

Båtsystem

STAINLESS

MP75, MPA75 - Monteringsanvisning

Båtsystem AB, Traneredsvägen 112, 426 53 Västra Frölunda, Tel: 031-69 03 80, Fax: 031-690097, www.batsystem.se, info@batsystem.se

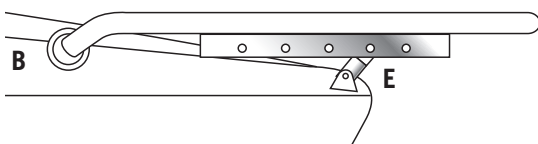
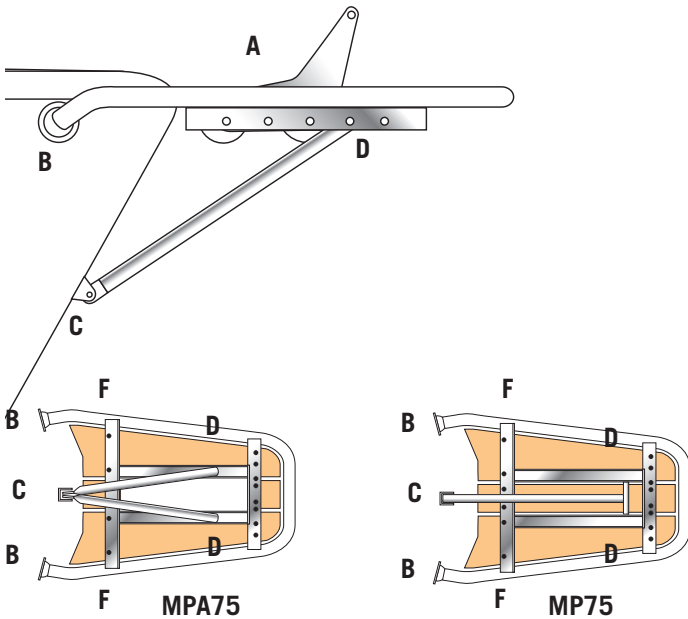

Alternativ montering: Montering på fördäck

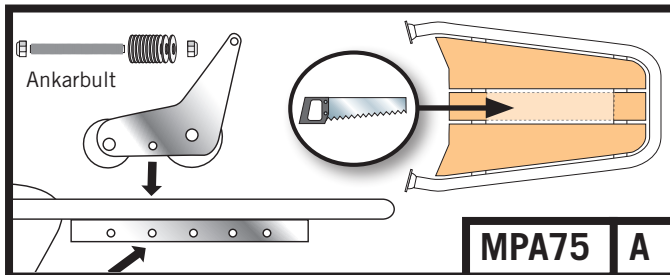

Ankarhållaren sänks ner i träöppningen som sågas upp och fästs med ankarbulten i andra hålet i skenan.

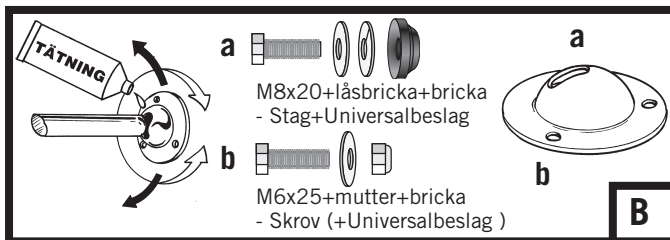

Plattformen fästs i skrovet med universalbeslagen på 2 ställen. Täta med sikaflex eller liknande vid infästningarna.

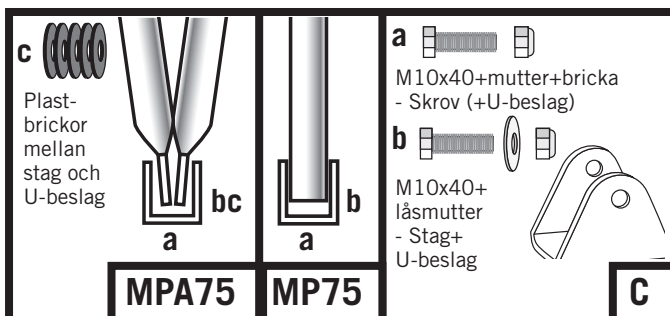

U-beslaget fästs i skrovet med genomgående bultar.

Monteringssats:

1 st	Peke (MP75)
1 st	Ankarhållare - till MPA75
2 st	Universalfästen inkl M8 x 30 + låsbricka + bricka
6 st	M6 x 25 inkl mutter o bricka
4 st	M10 x 50 inkl mutter o bricka
3 st	M10 x 40 + låsmutter
2 st	M10 x 20 + mutter
1 st	Stag (T-format) - till MP75
2 st	Stag (Ø25, 650 mm) - till MPA75
2 st	Ändplugg Ø25 mm
2 st	U-beslag
1 st	Ankarbult + 2 låsmutter och 10 brickor - till MPA75
5 st	Plastbrickor - till MPA75
2 st	Plastbrickor Ø34 mm

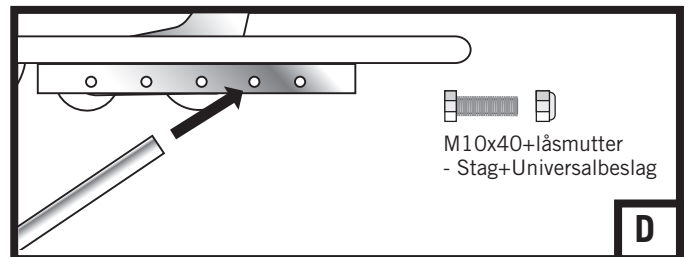
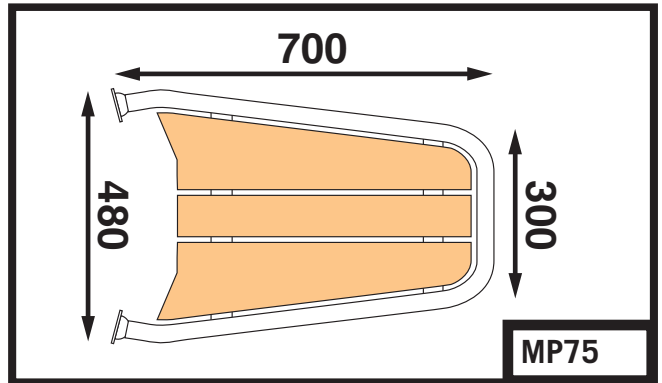

Stagen (2 st MPA75)/ staget (T-format) kapas efter behov och skruvas fast i plattformens skenor i lämpligt håll.

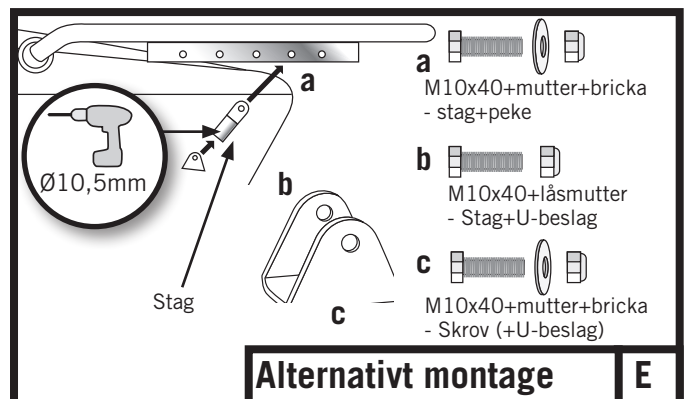

Stagen / staget kapas och skruvas fast i plattformens skenor.

Drag åt spännbultarna som drar ihop ramen.

F



MP75, MPA75 - Montering, tillbehör

Båtsystem AB, Traneredsvägen 112, 426 53 Västra Frölunda, Tel: 031-69 03 80, Fax: 031-690097, www.batsystem.se, info@batsystem.se

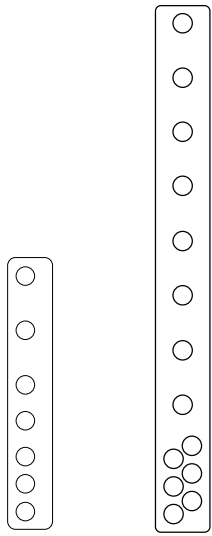

P1074
150x25 mm

P1091
290x30 mm

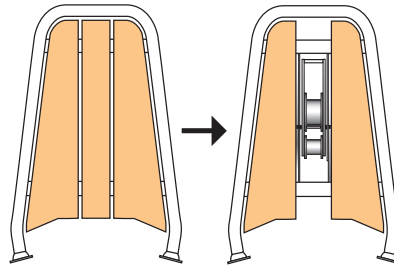

alt.

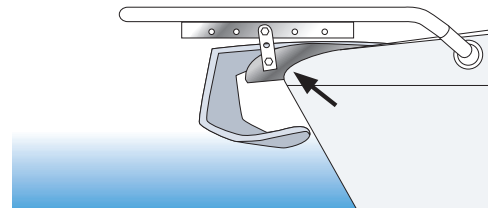
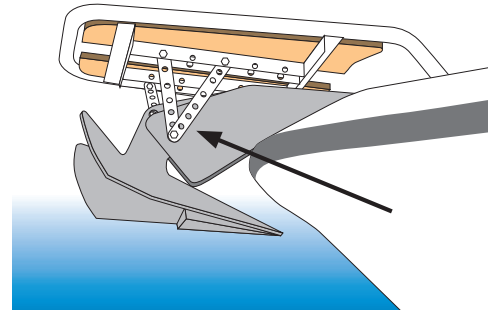
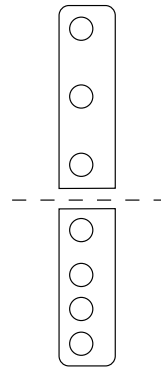

P1010
50 mm

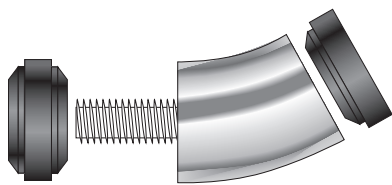
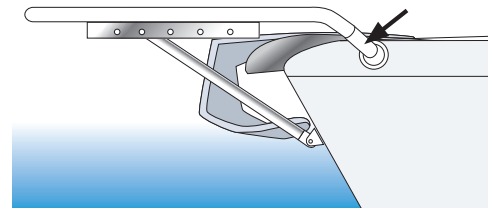

P1085
30°

alt.

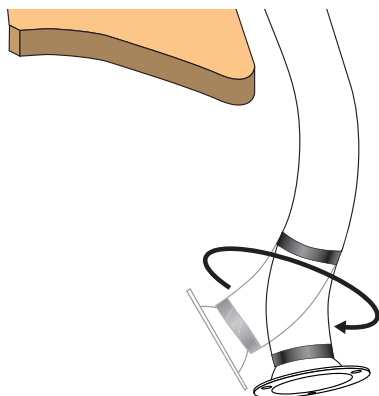
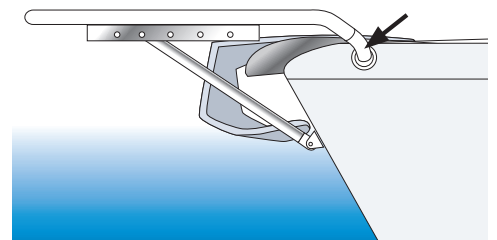

alt.

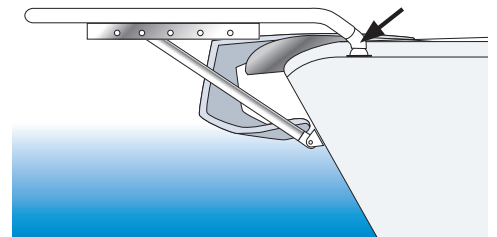

alt. etc

